

PowerCube
Purchase Approval form
 For PowerCube
 Linear Belt (PLB) components

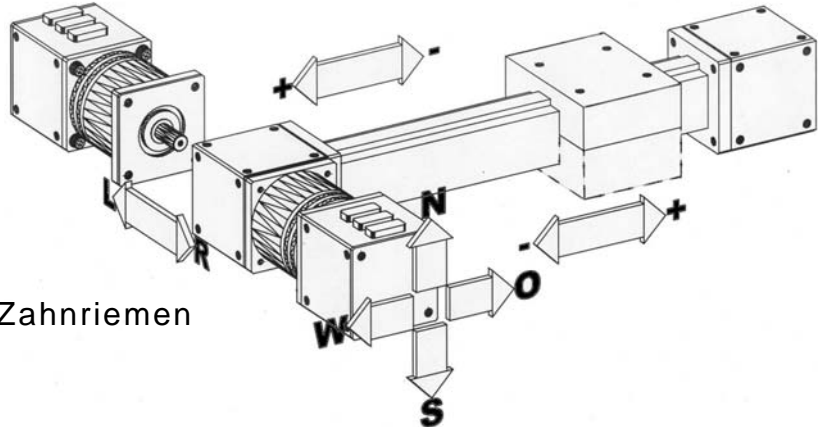

PowerCube Bestellformular
 Für Linearantriebsachsen mit Zahnriemen

PO# / Auftragsnummer: Date / Datum:

Amount/Anzahl: Signature / Unterschrift:

Type / Typ:	<input type="checkbox"/> PLB 070 <input type="checkbox"/> PLB 090 <input type="checkbox"/> PLB 110	Module Address (ID 1..31):	
Comm-Interface:	CAN [kbit/s] <input type="checkbox"/> 75 <input checked="" type="checkbox"/> 250* <input type="checkbox"/> 500 <input type="checkbox"/> 1000	RS232 [bit/s] <input type="checkbox"/> 1200 <input type="checkbox"/> 19200 <input type="checkbox"/> 2400 <input type="checkbox"/> 38400 <input type="checkbox"/> 4800 <input type="checkbox"/> 57600 <input checked="" type="checkbox"/> 9600* <input type="checkbox"/> 115200	PROFIBUS-DP <input type="checkbox"/> auto detect*
I/O Interface:	<input checked="" type="checkbox"/> Type I (DIO = 4 I/O)*	<input type="checkbox"/> Type II (ESO = Encoder Output)	<input type="checkbox"/> Type III (ESI = Encoder Input)
Internal 24 V supply for I/O Interface Interne 24 V Versorgung des I/O Interface:	<input type="checkbox"/> no	<input checked="" type="checkbox"/> yes*	
Magnetic Brake/Magnetbremse:	<input checked="" type="checkbox"/> no*	<input type="checkbox"/> yes	
Gear Head / Getriebe:	<input checked="" type="checkbox"/> 100:1*	<input type="checkbox"/> 50:1	
Double Sided Slide/O-Schlitten:	<input checked="" type="checkbox"/> no*	<input type="checkbox"/> yes	
Min. Stroke /Min. Hub: mm		
Max Length / Max Länge: mm (Length over all)		
Connector / Stecker:	<input checked="" type="checkbox"/> N* <input type="checkbox"/> E	<input type="checkbox"/> S <input type="checkbox"/> W	
Motor / Motoranschluß:	<input checked="" type="checkbox"/> R*	<input type="checkbox"/> L	
Home Position / Referenz Pos:	<input checked="" type="checkbox"/> Motor side / Motor*	<input type="checkbox"/> opposite / gegenüber	
Ballows / Faltenbalg:	<input checked="" type="checkbox"/> no*	<input type="checkbox"/> yes	

* Default setting / Voreinstellung

Please send this form to / Bitte senden Sie das Formular an: amtec robotics GmbH, Pankstrasse 8-10, D-13127 Berlin,
 Fax **++49+30 - 474 868 39**, Tel ++49+30 - 474 868 30, info@amtec-robotics.com, www.powercube.de